



LIQUID LEVEL GAGES SERIES 32

Section: J100
 Bulletin: J100.10
 Date: 1/1/99
 Supersedes: 32

Specialists in Liquid Level Indication For Pressures Up To 4000 psi @ 100°F

A Rugged Flat Glass Gage For High Pressure Applications

- Tempered Borosilicate Glass conforming to BS3463, JIS B8211, DIN 7080 and DIN 7081.
- All Gages are Hydrostatically Tested to 1 1/2 times the rated pressure at 100°F (38°C).
- Wetted Parts conform to NACE MR-01-75
- All Parts are ASTM Grade and listed in ASME 31.3
- Recessed Gasket Seat in Chamber and Cover
- Covers are Shrouded to Protect the Glass Edges

Standard construction includes a solid one-piece chamber machined from bar, steel covers, tempered glass, alloy steel bolts and nuts. Recessed gasket seats prevent gasket movement. Series 32 gages are available in a variety of materials to meet specific corrosive conditions.

Refer to the Gage Accessories bulletin J100.31 for non-frost extensions, illuminators, support brackets, Neoflon CTFE shields, Mica shields, and special alloys.

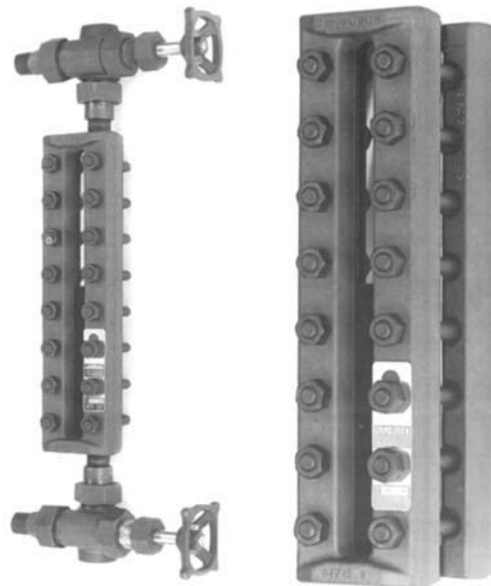

PRESSURE/TEMPERATURE RATINGS (PSIG) Note: Flanged gages are derated to flange rating.

REFLEX GAGE		
Temperature		Glass Size 1 thru 9
° F	° C	
100	38	4000
200	93	3890
300	149	3790
400	204	3700
500	260	3470
600	316	3080
700	371	2690
800	427	2300
SATURATED STEAM RATING 300 WSP		

TRANSPARENT GAGE		
Temperature		Glass Size 1 thru 9
° F	° C	
100	38	3000
200	93	2920
300	149	2850
400	204	2780
500	260	2600
600	316	2310
700	371	2020
800	427	1730
SATURATED STEAM RATING 750 WSP		

▲ For temperatures above 600°F (316°C) Aluminosilicate Glass **MUST** be used.

% of Rating	100%	90%	50%
Chamber Material	Carbon Steel, Stainless Steel Series 316 or 316L	Monel	Brass
Gasketing	Bonded Compressed Fibers or Teflon Glass Filled		Pure Teflon Neoflon CTFE (Shields)

Specify Gage Assemblies by the Figures Below

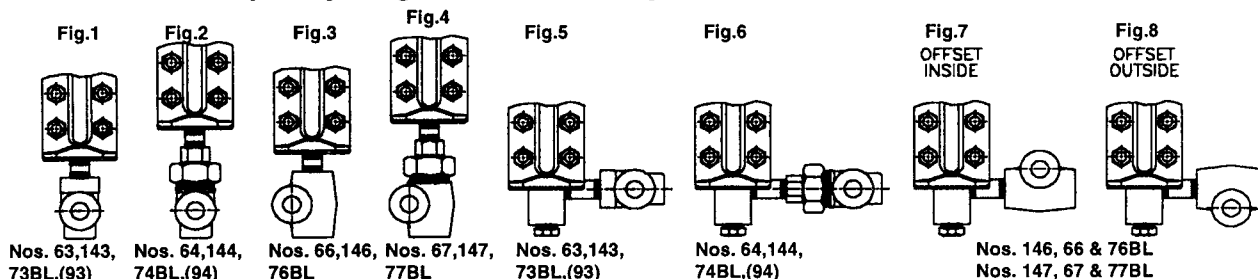

Specify Jerguson - All Gages are **NOT** Created Equal!

Liquid Level Gages and Valves for the Power and Process Industries

SERIES 32 LIQUID LEVEL GAGES

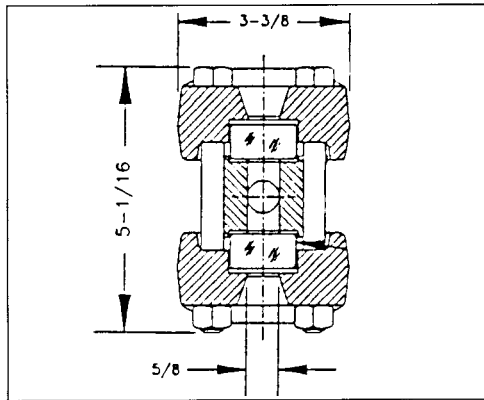
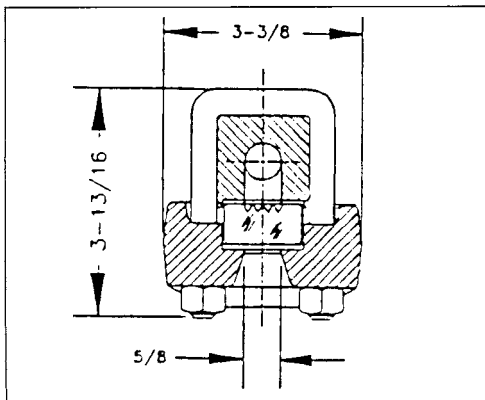

SERIES R-32

SERIES T-32

Sect. X Size	Visible Range		Overall Length		Approximate Weight			
					Reflex, R-32		Transp., T-32	
	inches	mm	inches	mm	lbs	Kgs	lbs	Kgs
11	3 3/4	95	5 1/4	133	8	3.6	10	4.5
12	4 3/4	121	6 3/4	159	9	4.1	14	6.4
13	5 3/4	146	7 3/4	184	11	5.0	17	7.7
14	6 3/4	171	8 3/4	210	12	5.5	19	8.6
15	7 3/4	200	9 3/4	238	14	6.4	21	9.5
16	9 3/4	232	10 3/4	270	16	7.3	24	10.9
17	10 3/4	260	11 3/4	298	18	8.2	27	12.3
18	11 3/4	302	13 3/4	340	20	9.1	30	13.6
19	12 3/4	321	14 3/4	359	21	9.5	32	14.5
23	13	330	14 1/2	368	22	10.0	33	15.0
24	15	381	16 1/2	419	25	11.4	38	17.3
25	17 1/4	438	18 3/4	476	28	12.7	43	19.5
26	19 3/4	502	21 1/4	540	32	14.5	49	22.3
27	22	559	23 1/2	597	35	15.9	54	24.5
28	25 1/4	641	26 3/4	679	40	18.2	61	27.7
29	26 3/4	679	28 3/4	718	43	19.5	64	29.1
36	30 3/4	772	31 3/4	810	48	21.8	73	33.2
37	33 3/4	857	35 1/4	895	53	24.1	80	36.4
38	38 3/4	981	40 3/4	1019	60	27.3	92	41.8
39	40 3/4	1038	42 3/4	1076	64	29.1	97	44.1
47	45 1/2	1156	47	1194	71	32.3	107	48.6
48	52	1321	53 1/2	1359	80	36.4	122	55.5
49	55	1397	56 1/2	1435	85	38.6	129	58.6
57	57 1/2	1454	58 3/4	1492	88	40.0	134	60.9
58	65 3/4	1661	66 3/4	1699	100	45.5	152	69.1
59	69 3/4	1756	70 3/4	1794	106	48.2	161	73.2
68	78 3/4	2000	80 3/4	2038	120	54.5	187	85.0
69	83 3/4	2115	84 3/4	2153	127	57.7	196	89.1
78	92 3/4	2340	93 3/4	2378	140	63.6	221	100.5
79	97 3/4	2473	98 3/4	2511	148	67.3	230	104.5
88	105 1/2	2680	107	2718	160	72.7	254	115.5
89	111 1/2	2832	113	2870	169	76.8	265	120.5

SPECIFICATIONS

SECTION LENGTHS:

Gage sections are available in nine standard glass sizes. Longer sizes are constructed with multiple vision slots in a continuous solid bar chamber.

CONNECTIONS:

Standard connections are at top and bottom and are 1/2 or 3/4 NPT female. Optional connections are available, such as socket weld, flanged or close hook-up (side/side).

LIQUID CHAMBER:

Machined from bar stock. The gasket seat is recessed to allow lateral support and facilitate positioning.

COVERS:

Forged carbon steel is standard. Optional materials are available. The cushion gasket seat is recessed.

BOLTS & NUTS

Alloy steel is standard, A193 B7 and A194 2H. Optional materials are available. All steel fasteners are "black oxide" treated to prevent rust.

GLASS:

Tempered Borosilicate is used to 600° F (316°). Aluminosilicate is used to 800° (427° C). Transparent glass may be protected from corrosive media with mica or Neoflon CTFE shields.

GASKETS:

Standard gaskets are precision die cut in proprietary Jerguson dies.

FINISH:

All steel parts are finish coated prior to assembly. Stainless steel is not coated.

VALVES:

Use of Jerguson gage valves is strongly recommended. Standard features include safety ball checks which help prevent loss of product and physical injury in the event of failure.



JERGUSON® GAGE AND VALVE

A Division of The Clark • Reliance® Corporation
16633 Foltz Industrial Parkway • Strongsville, OH 44149 USA
Telephone: (440) 572-1500 • Fax: (440) 238-8828